

Heat Pump Datasheet

Models:	EMA-4480-2-4(-SC)	EMA-4480-2-7(-SC)
Refrigerants:	R1234ze	R515B
Certification:	CE	CE
Safety class:	A2L	A1

The Energy Machines™ EMA model features two refrigerant circuits, each with two compressors. The unit contains a single evaporator and condenser. It offers an optional subcooling feature, allowing for efficient heat energy recovery between the condenser and expansion valve. This results in higher performance due to a greater energy uptake in the machine's evaporator process.

The EMA is designed to handle large pressure drops on the chilled and warm side using the machine's internal water pumps.

The EMA comes as a completely reversible heat pump in one unit.



Characteristics

Model characteristics	
Energy source	Ground, water, or waste heat
Compressor type	Scroll
Capacity control	4-Stepped
Features	Internal pumps
Option	Available with or without subcooler

Performance

Heating mode		Cooling mode	
Heating capacity (kW)	347	Heating capacity (kW)	542
HC with subcooler (kW)	464	HC with subcooler (kW)	686
Cooling capacity (kW)	229	Cooling capacity (kW)	438
CC with subcooler (kW)	345	CC with subcooler (kW)	582
Elec. power 4 compressors (kW)	119.4	Elec. power 4 compressors (kW)	104.6
COP without subcooler	2.91	COP without subcooler	4.19
COP with subcooler	3.89	COP with subcooler	5.57

HC = Heating capacity, CC = Cooling capacity, COP = Coefficient of performance

Design temperatures

Heating mode		Cooling mode	
Heated fluid (in/out)	47°C / 53°C	Heated fluid (in/out)	37°C / 43°C
Chilled fluid (in/out)	1°C / -3°C	Chilled fluid (in/out)	16°C / 10°C
Subcooler (in/out)	7°C / 39°C	Subcooler (in/out)	7°C / 29°C

Heated fluid: Water, Chilled fluid: Ethanol 26%

Flow and pressure

	Heating mode				Cooling mode		
	Heated fluid	Chilled fluid	Subcooler		Heated fluid	Chilled fluid	Subcooler
Flow (l/s)	13.8	20.2	0.88	Flow (l/s)	21.4	22.6	1.61
Pressure drop (kPa)	10	36	0.4	Pressure drop (kPa)	25	39	1.2
Available pressure (kPa)	166	85	57	Available pressure (kPa)	83	55	34

Specifications

Refrigerant			Ventilated enclosure*	
Safety class	A2L	A1	Minimum airflow (l/s)	93
Type	R1234ze	R515B	Pressure difference (Pa) shall be \geq	20
GWP	1.37	293	*Ventilation fan is not provided. Pressure difference is between enclosure interior and exterior. Applies only to EMA units with A2L refrigerants.	
Charge (kg)	26 + 26	26 + 26		

Flow diagram

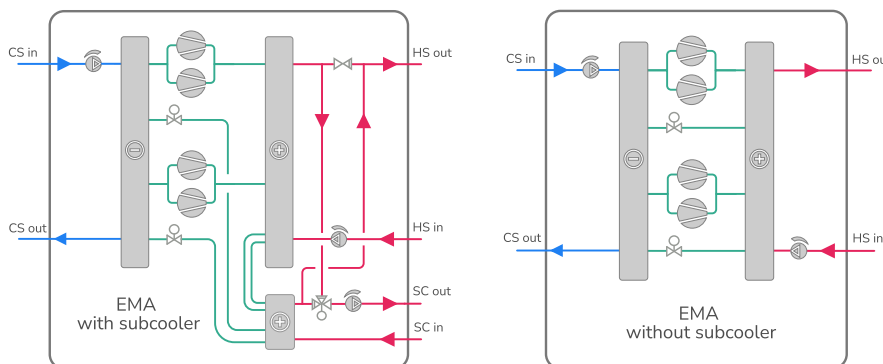

Dimensions

Electricity		Dimensions**	
Power supply voltage (VAC)	400	Length (mm)	2950
Power supply frequency (Hz)	50	Width (mm)	1140
Power supply phase (ϕ)	3	Height (mm)	1845
Rated power input (kW)	172	Dry weight (kg)	2700
Rated current (A)	293	Commissioned weight (kg)	3000
Rated start current (A)	394	**See dimensional drawings for clearance requirements	
Fuse (A)	315		

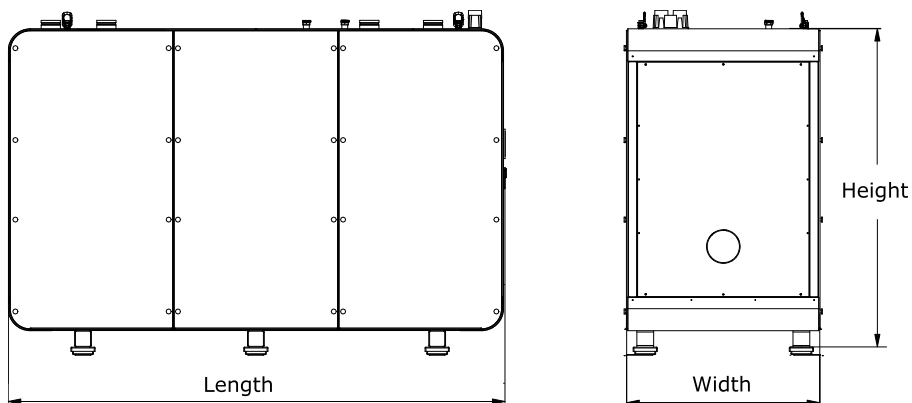

Energy Machines has a policy of continuous product and data improvement and reserves the right to change design and specifications without notice. While Energy Machines strives for accuracy, it does not guarantee the completeness or correctness of the information provided.



Energy Machines ApS Denmark Nicolai Eigtveds Gade 26, 1402 Copenhagen | Niels Jernes Vej 14, 9220 Aalborg Ø
Energy Machines Oy Finland Emäsalontie 271, 06950 Emäsalo Energy Machines Inc. USA 110 East 25th Street, New York, NY 10010
Energy Machines AB Sweden Norra Skeppsbron 15, 803 10 Gävle | Regnbågsgatan 3, 417 55 Gothenburg
Mariehällsvägen 37 F, 168 65 Bromma | Hyllie Boulevard 34, 21532 Malmö
hello@energymachines.com | energymachines.com