

Heat Pump Datasheet

Models:	EMB-4387-2-4	EMB-4387-2-7
Refrigerants:	R-1234ze	R-515B
Certification:	CE	CE
Safety class:	A2L	A1

The Energy Machines™ EMB models are designed for space heating, warm tap water production, and comfort cooling. They contain either one or two refrigerant circuits with two compressors in each.

The EMB models operate with either one or two heat source circuits containing brine. These circuits have an integrated circulation pump and switch between the production of hot tap water and the production of heat.

The EMB comes as a completely reversible heat pump in one unit.



Characteristics

Model characteristics	
Energy source	Ground, water, or waste heat
Compressor type	Scroll
Capacity control	2-Stepped
Features	Internal pumps

Performance

Heating mode		Cooling mode	
Heating capacity (kW)	289	Heating capacity (kW)	449
Cooling capacity (kW)	188	Cooling capacity (kW)	364
Elec. comp. total (kW)	102.5	Elec. comp. total (kW)	173.6
COP	2.84	COP	4.19

COP = Coefficient of performance

Design temperatures

Heating mode		Cooling mode	
Heated fluid (in/out)	47°C / 53°C	Heated fluid (in/out)	37°C / 43°C
Chilled fluid (in/out)	1°C / -3°C	Chilled fluid (in/out)	15°C / 10°C

Heated fluid: Water, Chilled fluid: Ethanol 26%

Flow and pressure

Heating mode			Cooling mode		
	Heated fluid	Chilled fluid		Heated fluid	Chilled fluid
Flow (l/s)	12	14	Flow (l/s)	17.9	17.8
Pressure drop (kPa)	5	12	Pressure drop (kPa)	11	24
Available pressure (kPa)	115	102	Available pressure (kPa)	84	56

Flow diagram

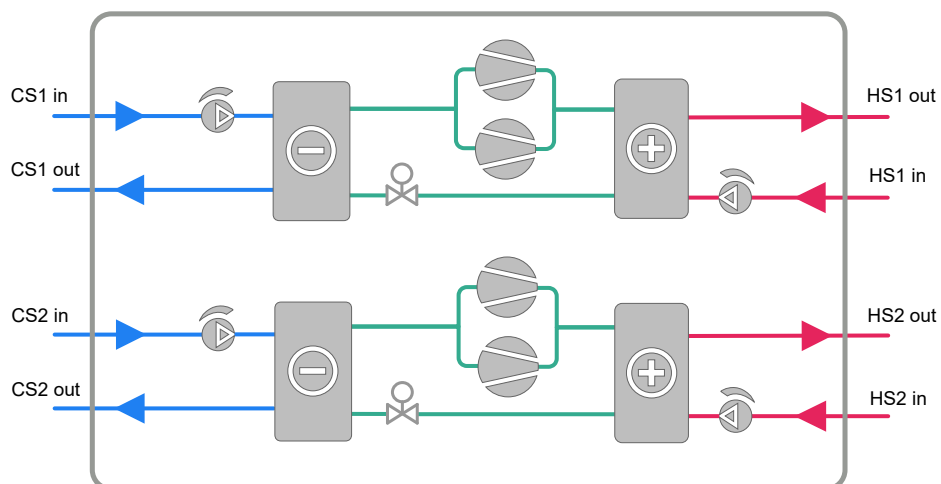

Specifications

Refrigerant		
Type	R-1234ze	R-515B
GWP	1.37	293
Charge (kg)	14+14	

Ventilated enclosure*	
Minimum airflow (l/s)	50
Pressure difference (Pa) shall be \geq	20

*Ventilation fan is not provided. Pressure difference is between enclosure interior and exterior. Applies only to units with A2L refrigerants.

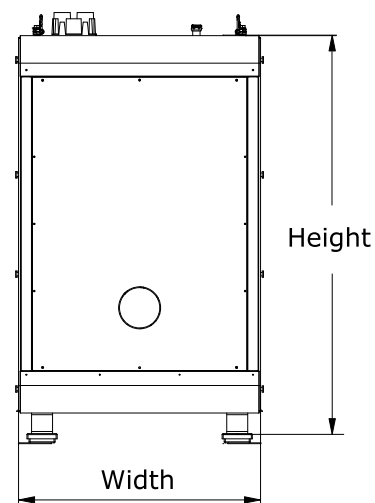
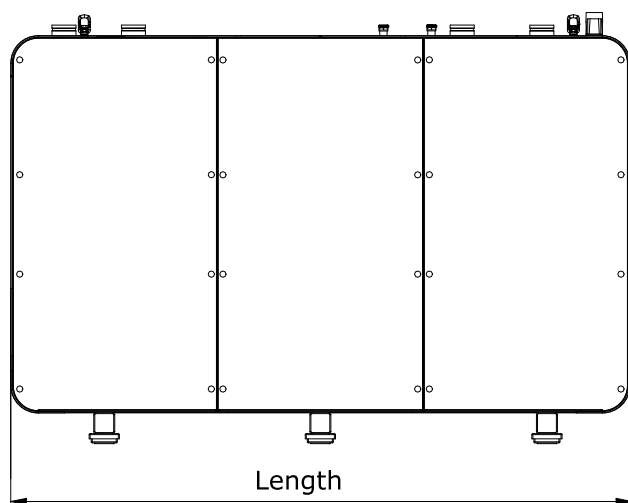

Electricity	
Power supply voltage (VAC)	400
Power supply frequency (Hz)	50
Power supply phase (ϕ)	3
Rated power input (kW)	157
Rated current (A)	277
Rated start current (A)	392
Fuse (A)	315

Dimensions**	
Length (mm)	2950
Width (mm)	1140
Height (mm)	1845
Dry weight (kg)	2300
Commissioned weight (kg)	2700
**See dimensional drawings for clearance requirements	

Energy Machines has a policy of continuous product and data improvement and reserves the right to change design and specifications without notice. While Energy Machines strives for accuracy, it does not guarantee the completeness or correctness of the information provided.



Energy Machines ApS Denmark Nicolai Eigtveds Gade 26, 1402 Copenhagen | Niels Jernes Vej 14, 9220 Aalborg Ø
Energy Machines Oy Finland Emäsalontie 271, 06950 Emäsalo Energy Machines Inc. USA 110 East 25th Street, New York, NY 10010
Energy Machines AB Sweden Norra Skeppsbron 15, 803 10 Gävle | Regnbågsgatan 3, 417 55 Gothenburg
Mariehällsvägen 37 F, 168 65 Bromma | Hyllie Boulevard 34, 21532 Malmö
hello@energymachines.com | energymachines.com