

Heat Pump Datasheet

Model:	EMF-2220-2-8
Refrigerants:	R290
Certification:	CE
Safety class:	A3

The Energy Machines™ EMF model combines efficiency, capacity modulation, and flexible installation options.

It features two independent refrigerant circuits that use natural refrigerants together with scroll compressors and frequency inverters, delivering excellent part-load performance and dependable capacity.

The EMF model is specifically designed for heating and cooling applications. Each circuit carries a refrigerant charge below 5 kg, enabling more versatile installation possibilities. With integrated controls for circulation pumps and control valves, the EMF delivers a complete heat pump and cooling solution in a single unit.



Characteristics

Model characteristics	
Energy source	Ground, water, or waste heat
Compressor type	Scroll
Capacity control	Frequency controlled
Features	High capacity control range

Performance

Heating mode		Cooling mode	
Heating capacity (30-140 Hz)	17 - 164 kW	Heating capacity (30-140 Hz)	27 - 241 kW
Cooling capacity (30-140 Hz)	12 - 109 kW	Cooling capacity (30-140 Hz)	22 - 190 kW
COP (60 Hz)	2.90	COP (60 Hz)	4.30
COP (140 Hz)	2.65	COP (140 Hz)	3.30

COP = Coefficient of performance

Design temperatures

Heating mode		Cooling mode	
Heated fluid (in/out)	47°C / 53°C	Heated fluid (in/out)	37°C / 43°C
Chilled fluid (in/out)	1°C / -3°C	Chilled fluid (in/out)	15°C / 10°C

Chilled fluid = ethanol 26%, Heated fluid = water.

Flow and pressure drop

Heating mode			Cooling mode		
	Heated fluid	Chilled fluid		Heated fluid	Chilled fluid
Flow (30-140 Hz)	0.7 - 6.5 l/s	0.7 - 6.3 l/s	Flow (30-140 Hz)	1.1 - 9.6 l/s	1.0 - 8.8 l/s
Pressure drop (140 Hz)	30 kPa	20 kPa	Pressure drop (140 Hz)	65 kPa	35 kPa

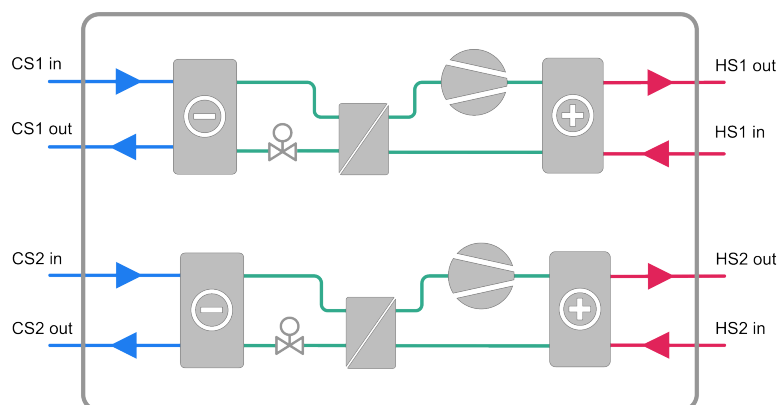

Specifications

Refrigerant	
Type	R290
GWP	0.02
Charge, C1 + C2 (kg)	4.5 + 4.5

Ventilated enclosure	
Minimum airflow [Qmin] (l/s)	42
Pressure difference (Pa) shall be \geq	20

Note: The ventilation fan is not provided. The pressure difference refers to the difference between the inside and outside of the ventilated enclosure.

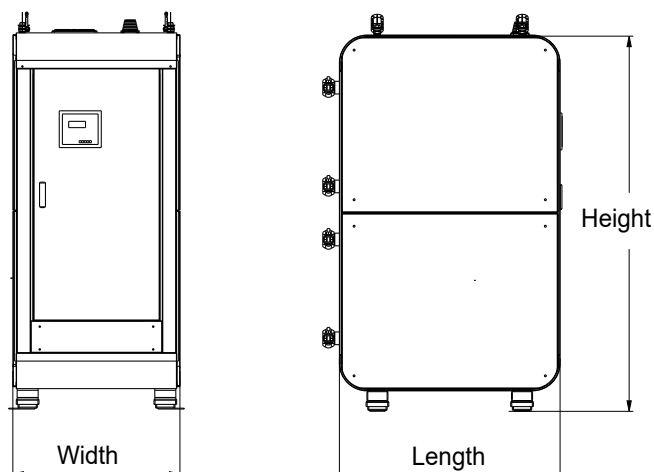

Electricity	
Power supply voltage (VAC)	400
Power supply frequency (Hz)	50
Power supply phase (ϕ)	3
Rated power input (kW)	70
Rated current (A)	112
Fuse (A)	125

Dimensions*	
Length (mm)	1250
Width (mm)	795
Height (mm)	1743
Dry weight (kg)	650
Commissioned weight (kg)	750
*See dimensional drawings for clearance requirements	

Energy Machines has a policy of continuous product and data improvement and reserves the right to change design and specifications without notice. While Energy Machines strives for accuracy, we do not guarantee the completeness or correctness of the information.



Energy Machines ApS Denmark Nicolai Eigtveds Gade 26, 1402 Copenhagen | Niels Jernes Vej 14, 9220 Aalborg Ø
Energy Machines Oy Finland Emäsalontie 271, 06950 Emäsalo Energy Machines Inc. USA 110 East 25th Street, New York, NY 10010
Energy Machines AB Sweden Norra Skeppsbron 15, 803 10 Gävle | Regnbågsgatan 3, 417 55 Gothenburg
Mariehällsvägen 37 F, 168 65 Bromma | Hyllie Boulevard 34, 21532 Malmö
hello@energymachines.com | energymachines.com