

Heat Pump Datasheet

Models:	EMHP-60F-60F-2-4	EMHP-60F-60F-2-7
Refrigerant:	R1234ze	R515B
Certification:	CE	CE
Safety class:	A2L	A1

This Energy Machines™ EMHP model contains two refrigerant circuits with a semi-hermetic reciprocating compressor in each. Together with frequency inverters, the EMHP model has the capability of providing either high turndown or extra capacity when required. The two refrigerant circuits are completely independent, ensuring the stability of the heating supply.

The EMHP model is specifically designed for heating and cooling purposes. It can handle large pressure drops on the water side using the machine's internal water pumps.

The EMHP comes as a complete heat pump and cooling system in one unit.



Characteristics

Model characteristics	
Energy source	Ground, water, or waste heat
Compressor type	Reciprocating
Capacity control	Frequency controlled, PWM
Special features	Frequency option, high capacity control range, internal pumps

Performance

Heating mode		
Circuit	C1	C2
Heating capacity (kW)	81	81
Total heating capacity (kW)	161	
Cooling capacity (kW)	54	54
Total cooling capacity (kW)	108	
COP	3.04	3.04

Cooling mode		
Circuit	C1	C2
Heating capacity (kW)	147	147
Total heating capacity (kW)	294	
Cooling capacity (kW)	116	116
Total cooling capacity (kW)	232	
COP	3.72	3.72

COP = Coefficient of performance

Design temperatures

Heating mode	
Heated fluid (in/out)	47°C / 53°C
Chilled fluid (in/out)	1°C / -3°C

Cooling mode	
Heated fluid (in/out)	37°C / 43°C
Chilled fluid (in/out)	15°C / 10°C

Chilled fluid = ethanol 26%, Heated fluid = water

Flow and pressure

Heating mode				
	Heated fluid		Chilled fluid	
Circuit	C1	C2	C1	C2
Flow (l/s)	3.21	3.21	3.31	3.31
Pressure drop (kPa)	6.8	6.8	7.4	7.4
Available pressure (kPa)	128	128	128	128

Cooling mode				
	Heated fluid		Chilled fluid	
Circuit	C1	C2	C1	C2
Flow (l/s)	5.87	5.87	5.67	5.67
Pressure drop (kPa)	21.1	21.1	16.6	16.6
Available pressure (kPa)	101	101	108	108

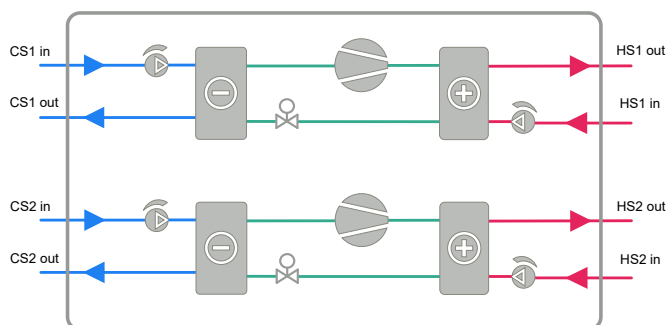

Specifications

Refrigerant		
Type	R1234ze	R515B
GWP	1.37	293
Charge (kg)	12 + 12	

Ventilated enclosure*	
Minimum airflow [Qmin] (l/s)	45
Pressure difference (Pa) shall be ≥	20

*Ventilation fan is not provided. Pressure difference is between enclosure interior and exterior. Applies only to units with A2L refrigerants.

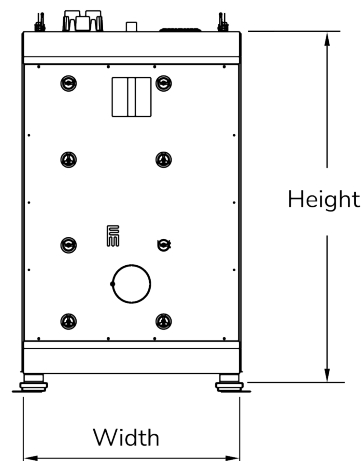
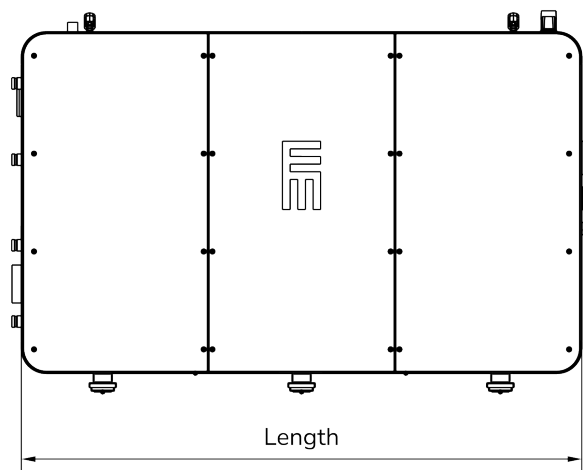

Electricity	
Power supply voltage (VAC)	400
Power supply frequency (Hz)	50
Power supply phase (ϕ)	3
Rated power input (kW)	105
Rated current (A)	194
Fuse (A)	200

Dimensions**	
Length (mm)	2950
Width (mm)	1160
Height (mm)	1845
Dry weight (kg)	2650
Commissioned weight (kg)	2950
**See dimensional drawings for clearance requirements	

Energy Machines has a policy of continuous product and data improvement and reserves the right to change design and specifications without notice. While Energy Machines strives for accuracy, it does not guarantee the completeness or correctness of the information provided.



Energy Machines ApS Denmark Nicolai Eigtveds Gade 26, 1402 Copenhagen | Niels Jernes Vej 14, 9220 Aalborg Ø
Energy Machines Oy Finland Emäsalontie 271, 06950 Emäsalo Energy Machines Inc. USA 110 East 25th Street, New York, NY 10010
Energy Machines AB Sweden Norra Skeppsbron 15, 803 10 Gävle | Regnbågsgatan 3, 417 55 Gothenburg
Mariehällsvägen 37 F, 168 65 Bromma | Hyllie Boulevard 34, 21532 Malmö
hello@energymachines.com | energymachines.com