

EMT heat pump

Datasheet

EMT-2285-2-4-ECO (R1234ze)

EMT-2285-2-7-ECO (R515B)

This Energy Machines™ model contains two oil-free centrifugal turbocompressors and two refrigerant circuits. The compressors are classified as non-positive displacement compressors.

This model is equipped with two economizer heat exchangers, increasing its energy efficiency. The machine's evaporator and condenser are shell-and-tube heat exchangers. The evaporator operates with a flooded evaporation technique.

These components work together to create a powerful and efficient machine.



Performance

Winter (Heating mode)		Summer (Cooling mode)	
Heating power	694 kW	Heating power	711 kW
Cooling power	505 kW	Cooling power	551 kW
COP	3.68	COP	3.44

COP = Coefficient of performance

Design parameters

Winter (Heating mode)		Summer (Cooling mode)	
Heated fluid (in/out)	57°C / 63°C	Heated fluid (in/out)	37°C / 43°C
Chilled fluid (in/out)	12°C / 7°C	Chilled fluid (in/out)	12°C / 7°C

Chilled fluid= water, Heated fluid= water.

Pressure drop at rated flow

Winter (Heating mode)		Summer (Cooling mode)	
Heated fluid	44.8 kPa / 27.63 l/s	Heated fluid	47.8 kPa / 28.31 l/s
Chilled fluid	41.2 kPa / 24.13 l/s	Chilled fluid	48.1 kPa / 26.33 l/s

Flow diagram

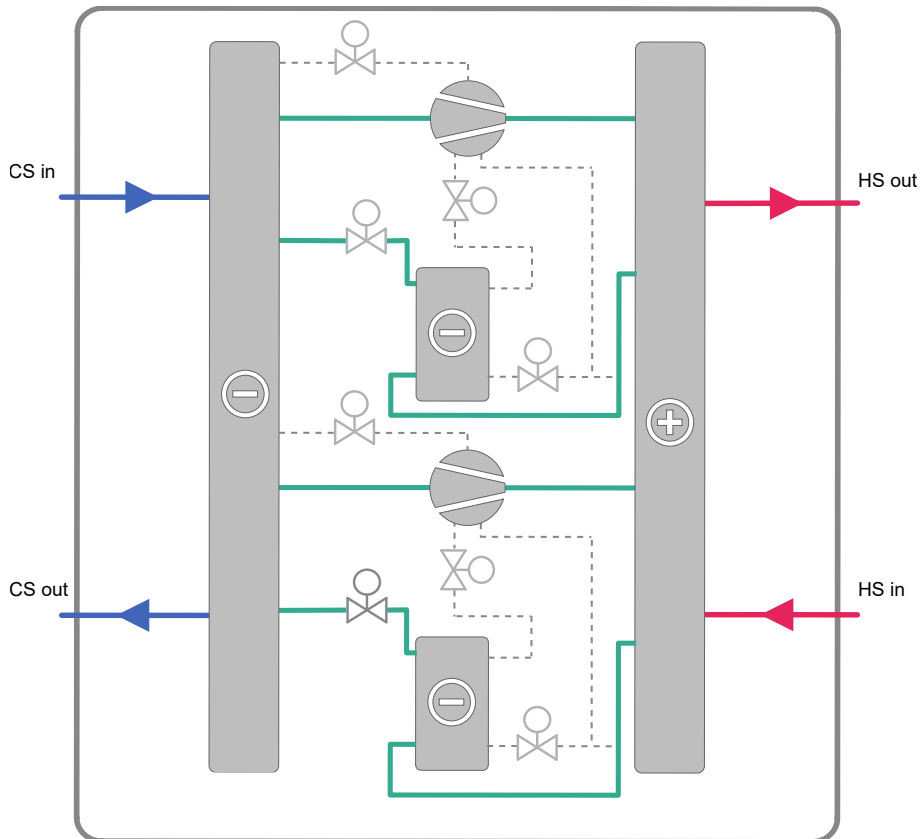

Specifications

Refrigerant			Dimensions	
Type	R1234ze	R515B	Length / Width / Height	4000mm / 1260mm / 1965mm
GWP value	1.37	288	Weight (dry/comm.)	~ N/A kg / N/A kg
Charge	N/A kg			

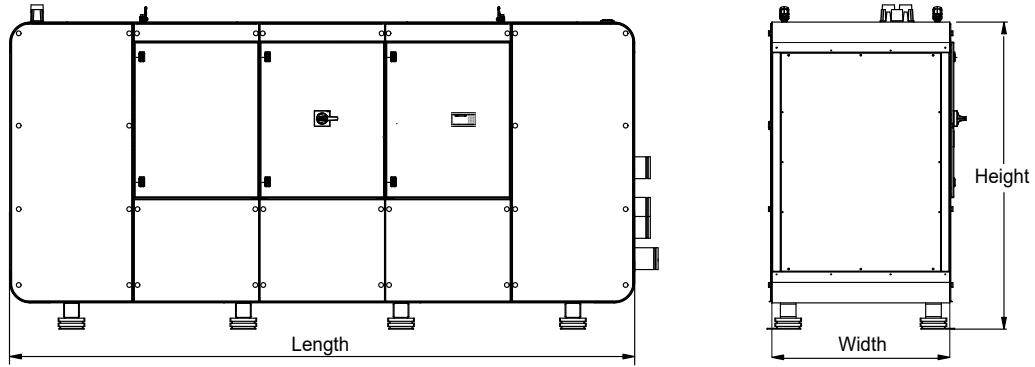

Electricity	
Rated power supply	400 VAC / 50 Hz / 3 phase
Rated power input	200 kW
Rated current	300 A
Fuse	400 A

Energy Machines has a policy of continuous product and data improvement and reserves the right to change design and specifications without notice. While Energy Machines strives for accuracy, we do not guarantee the completeness or correctness of the information

